



UNDERSTANDING THE RESIDENTIAL DEVELOPMENT STANDARDS

This Practice Note is an illustrative guide to the application of 14 residential development standards in Clauses 54 and 55 of all planning schemes in Victoria.

The purpose of this Practice Note is to ensure a common interpretation and consistent application of the 14 residential development standards that apply to all dwellings across all planning schemes in Victoria. The standards are:

- Street setback – Standard A3 and B6
- Building height – Standard A4 and B7
- Site coverage – Standard A5 and B8
- Permeability – Standard A6 and B9
- Parking provision – Standard A9 and B16
- Side and rear setbacks – Standard A10 and B17
- Walls on boundaries – Standard A11 and B18
- Daylight to existing windows – Standard A12 and B19
- North-facing windows – Standard A13 and B20
- Overshadowing open space – Standard A14 and B21
- Overlooking – Standard A15 and B22
- Daylight to new windows – Standard A16 and B27
- Private open space – Standard A17 and B28
- Front fences – Standard A20 and B32

Meeting the requirements of Clauses 54 and 55

This Practice Note is not a substitute for meeting the requirements of Clauses 54 and 55. Any application of the standards illustrated in this Practice Note cannot occur without considering the relevant objectives and decision guidelines in planning schemes. Some of the standards are also able to be locally varied and any applicable local schedules should also be consulted before considering the relevant standard.

Clauses 54 and 55 specify objectives that must be met. The objectives describe the desired outcome to be achieved by a development proposal. A development must meet all of the objectives of the clause before a permit can be issued.

Each objective contains a relevant standard. A standard contains the preferred requirements or measures to meet the objective. However, if the particular features of your site or the neighbourhood mean that application of the standard would not meet the objective, an alternative design solution that meets the objective is required. Remember, meeting the standard does not automatically mean that the objective has been met.

For detailed information on the operation of the objectives, standards and decision guidelines, you should refer to Clauses 54 and 55 in all planning schemes.

The following Planning Practice Notes also provide assistance with aspects of the operation of the residential provisions in all planning schemes:

- *Understanding neighbourhood character*
- *Making a planning application for a dwelling in a residential zone*
- *Assessing a planning application for a dwelling in a residential zone*

Note: The drawings in this Practice Note are not drawn to scale and are indicative only for the purpose of illustrating the application of the standards.

A3 B6 Street setback

The setback of buildings from the street is a key determinant of neighbourhood character. This standard relates the front setback to neighbouring setbacks so all new buildings maintain the street's character.

Standard A3 and B6

Walls of buildings should be set back from streets:

- At least the distance specified in the schedule to the zone, or
- If no distance is specified in the schedule to the zone, the distance specified in Table A1/B6.

Porches, pergolas and verandahs that are less than 3.6 metres high and eaves may encroach not more than 2.5 metres into the setbacks of this standard.

Table A1 and B6 Street setback

DEVELOPMENT CONTEXT	MINIMUM SETBACK FROM FRONT STREET (METRES)	MINIMUM SETBACK FROM A SIDE STREET (METRES)
There is an existing building on both the abutting allotments facing the same street, and the site is not on a corner.	The average distance of the setbacks of the front walls of the existing buildings on the abutting allotments facing the front street or 9 metres, whichever is the lesser.	Not applicable
There is an existing building on one abutting allotment facing the same street and no existing building on the other abutting allotment facing the same street, and the site is not on a corner.	The same distance as the setback of the front wall of the existing building on the abutting allotment facing the front street or 9 metres, whichever is the lesser.	Not applicable
There is no existing building on either of the abutting allotments facing the same street, and the site is not on a corner.	6 metres for streets in a Road Zone, Category 1, and 4 metres for other streets.	Not applicable
The site is on a corner.	If there is a building on the abutting allotment facing the front street, the same distance as the setback of the front wall of the existing building on the abutting allotment facing the front street or 9 metres, whichever is the lesser. If there is no building on the abutting allotment facing the front street, 6 metres for streets in a Road Zone, Category 1, and 4 metres for other streets.	The same distance as the setback of the front wall of any existing building on the abutting allotment facing the side street or 2* metres, whichever is the lesser.

* The minimum setback from a side street is 2 metres for one dwelling on a lot (Clause 54) and 3 metres for two or more dwellings on a lot (Clause 55)

Applying the standard

Average front setback

The average front setback for the new dwelling is established by taking the front setbacks of the two existing dwellings (Setbacks A and B) on the abutting lots and dividing by two.

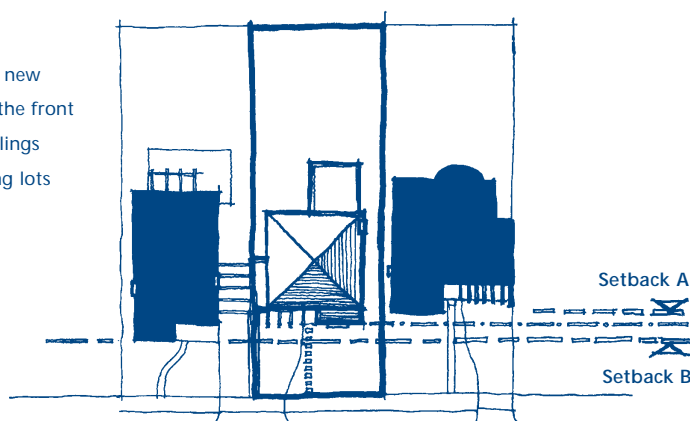

Front setback where there is only one existing abutting dwelling

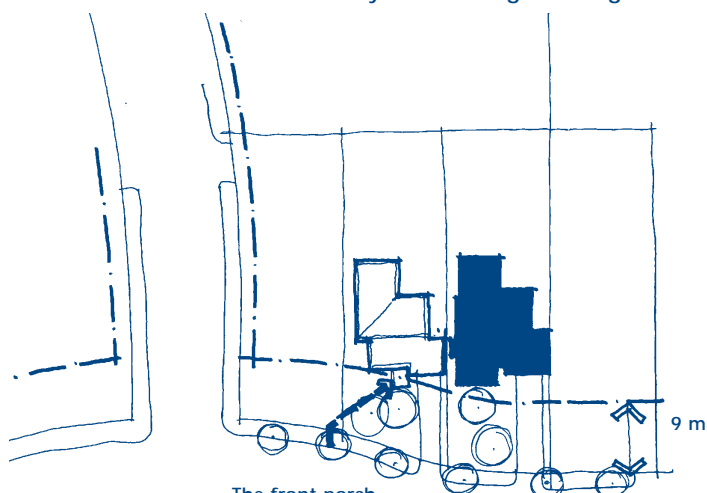

The front porch is an allowable encroachment

While the new dwelling takes its reference for front setback from the existing dwelling, in this instance the existing dwelling setback is greater than 9 metres. Therefore, the new dwelling is able to be setback 9 metres.

Front setback on a corner lot

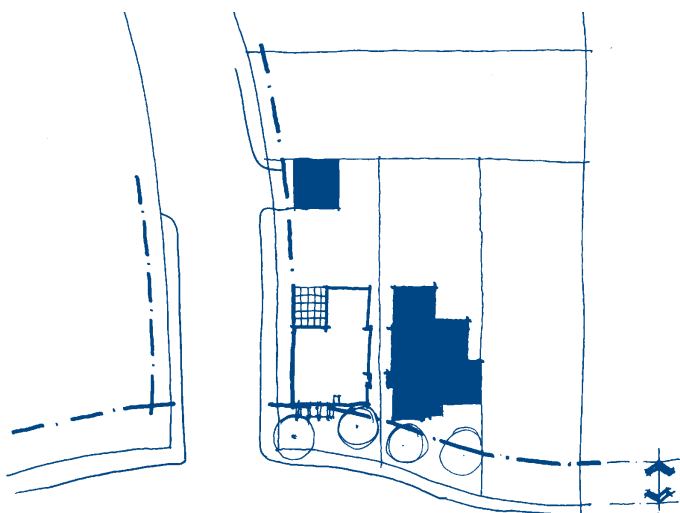

Same front setback as adjoining dwelling

Either street frontage may be selected as the front setback on a corner lot.

The new dwelling should be set back the same distance as the front setback of the abutting dwelling facing the same street.

Where there is a proposal to develop two or more dwellings on a lot, there is only one front street setback for the purposes of this standard.

Side setback on a corner lot

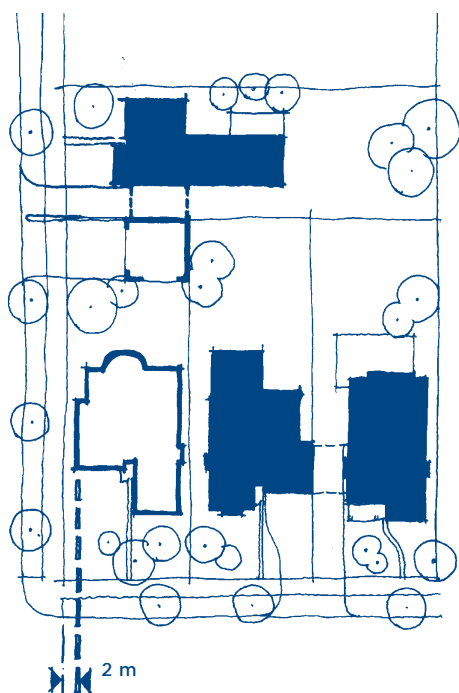

Once the front setback has been chosen, the other street frontage is treated as a side setback and the new dwelling is able to be setback 2 metres for one dwelling on a lot and 3 metres for two or more dwellings on a lot from that boundary.

A4 B7 Building height

Building height is an important aspect of both character and amenity in residential areas. The standard protects the amenity of properties near new development and ensures that excessive building height does not diminish the character of neighbourhoods.

Standard A4 and B7

The maximum building height should not exceed the maximum height specified in the schedule to the zone.

If no maximum height is specified in the schedule to the zone, the maximum building height should not exceed 9 metres, unless the slope of the natural ground level at any cross section wider than 8 metres of the site of the building is 2.5 degrees or more, in which case the maximum building height should not exceed 10 metres.

Changes of building height between existing buildings and new buildings should be graduated.

Applying the standard

Maximum building height on sloping land

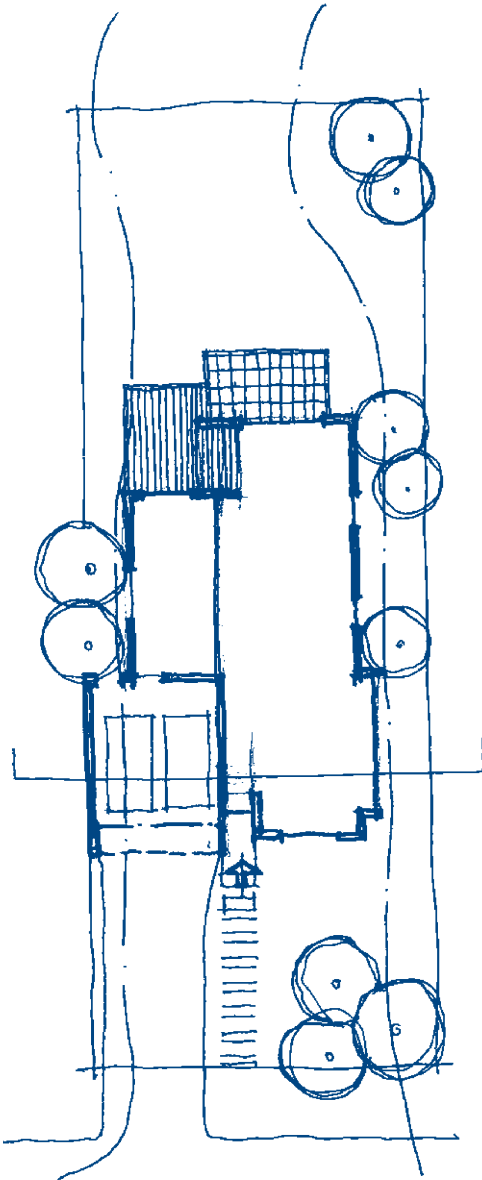

The slope of land is measured through any cross section (greater than 8 metres) of the building.

If the slope of the land is greater than 2.5 degrees through the cross section, the maximum building height may be up to 10 metres.

The maximum height of 10 metres is measured from any point of the dwelling to natural ground level.

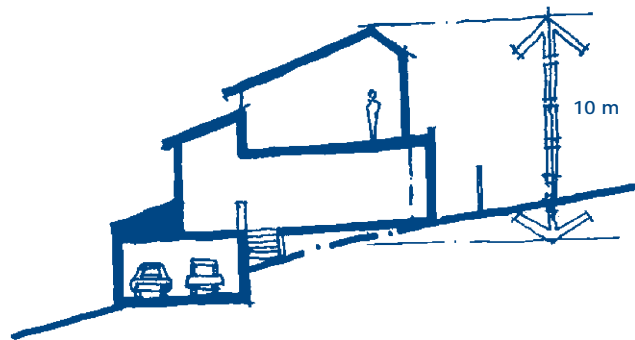

Graduating height



Working out the slope of a building site

Where the slope of the ground is 2.5° or more across an 8 m section of the building site, this is equal to a ratio of 1:23 or, expressed as a rise or fall over an 8 m section, is equal to 350 mm.

A5 B8 Site coverage

The standard limits the proportion of any lot that can be built on, to provide outdoor space for residents, and to protect the amenity and character of neighbourhoods.

Standard A5 and B8

The site area covered by buildings should not exceed:

- The maximum site coverage specified in the schedule to the zone, or
- If no maximum site coverage is specified in the schedule to the zone, 60 per cent.

Applying the standard

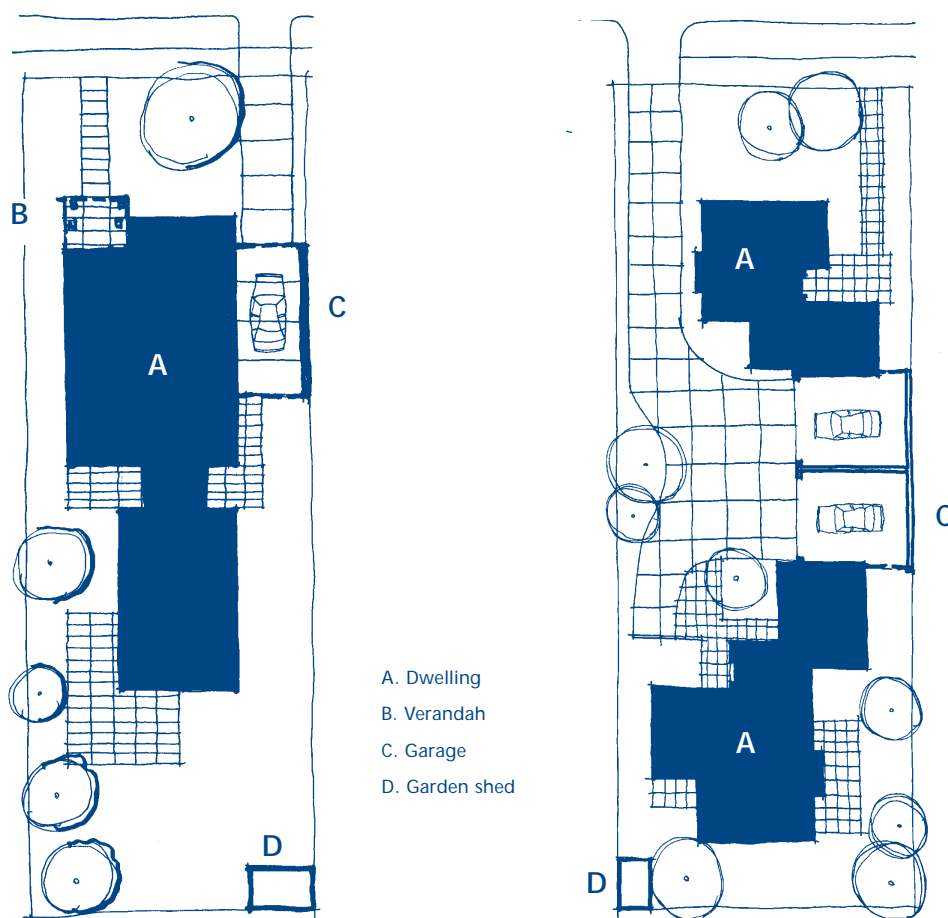

$$\text{Site coverage (\%)} = \frac{\text{Total building area} \times 100}{\text{Total site area}}$$

The definition of a building includes a dwelling, a garage or carport, a verandah and any other roofed building such as a garden shed. When calculating site coverage, if the upper storey projects over the ground floor, that part of the upper storey is also added onto the ground floor area.

Outdoor paving, driveways, footpaths or building eaves are not included when calculating the amount of site coverage.

In the above examples:-

When calculating site coverage for the single dwelling proposal, the total building area includes the dwelling, verandah, garage and garden shed.

When calculating site coverage for the two dwelling proposal, the total building area includes both dwellings, both garages and the garden shed for the second dwelling. Where there are two or more dwellings on a lot, the total site area for all the dwellings is included when calculating site coverage.

A6 B9 Permeability

Limiting hard surfaces reduces the volume of stormwater run-off, which reduces pressure on urban drainage systems and helps protect water quality in downstream waterways. This standard limits the amount of hard surfaces that can surround a new development.

Standard A6 and B9

At least 20 per cent of the site should not be covered by impervious surfaces.

Applying the standard

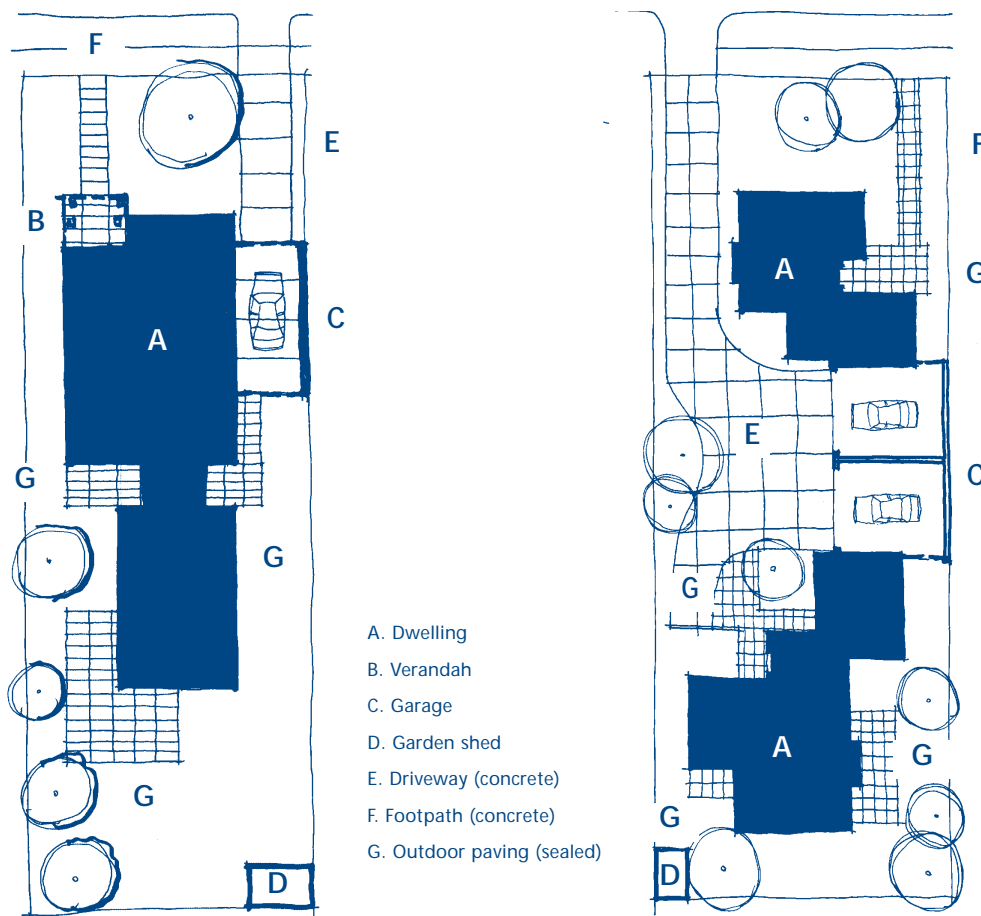

$$\text{Permeability (\%)} = \frac{\text{Total pervious area} \times 100}{\text{Total site area}}$$

Water cannot penetrate an impervious surface. An impervious surface includes a dwelling, a garage or carport, a verandah, a garden shed, a footpath, a swimming pool, outdoor paved areas, a driveway or any other sealed surface.

At least 20 per cent of the site should have surfaces that can absorb water – such as garden beds, lawn and other unsealed surfaces. This can include driveways, footpaths and outdoor entertaining areas, provided the materials used for their construction are pervious.

A9 B16 Parking provision

This standard ensures that all new development has appropriate on-site car parking, to contain demand for street parking, and that parking spaces are accessible and adequate in size.

Standard A9

Two car spaces should be provided per dwelling with:

- One space at least 6 metres long and 3.5 metres wide and covered or capable of being covered.
- The second space at least 4.9 metres long and 2.6 metres wide.

If the car spaces are provided in a garage, carport or otherwise constrained by walls, a double space may be 5.5 metres wide measured inside the garage or carport.

A building may project into a car space if it is at least 2.1 metres above the space.

The requirements of this standard do not apply to extensions to existing dwellings.

Standard B16

Car parking for residents should be provided as follows:

- One space for each one or two bedroom dwelling.
- Two spaces for each three or more bedroom dwelling, with one space under cover.

Studies or studios that are separate rooms must be counted as bedrooms.

Developments of five or more dwellings should provide visitor car parking of one space for every five dwellings. The spaces should be clearly marked as visitor parking.

In developments of five or more dwellings, bicycle parking spaces should be provided.

Car spaces and accessways should have the minimum dimensions specified in Table B2.

Table B2 Car park and accessway dimensions

ANGLE OF CAR SPACES TO ACCESSWAY	ACCESSWAY WIDTH	CAR SPACE WIDTH	CAR SPACE LENGTH
Parallel	3.6 m	2.3 m	6.7 m
45°	3.5 m	2.6 m	4.9 m
60°	4.9 m	2.6 m	4.9 m
90°	6.4 m	2.6 m	4.9 m
	5.8 m	2.8 m	4.9 m
	5.2 m	3.0 m	4.9 m
	4.8 m	3.2 m	4.9 m

A building may project into the space if it is at least 2.1 metres above the space.

Car spaces in garages, carports or otherwise constrained by walls should be at least 6 metres long and 3.5 metres wide for a single space and 5.5 metres wide for a double space measured inside the garage or carport.

Car parking facilities should:

- Be designed for efficient use and management.
- Minimise the area of hard surface.
- Be designed, surfaced and graded to reduce run-off and allow stormwater to drain into the site.
- Be lit.

Applying the standard

Garage dimensions

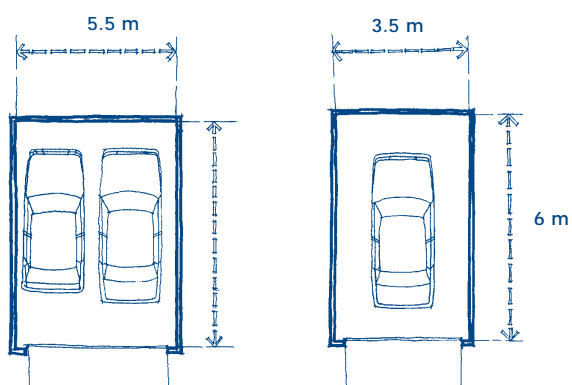

Provision of two car spaces in tandem

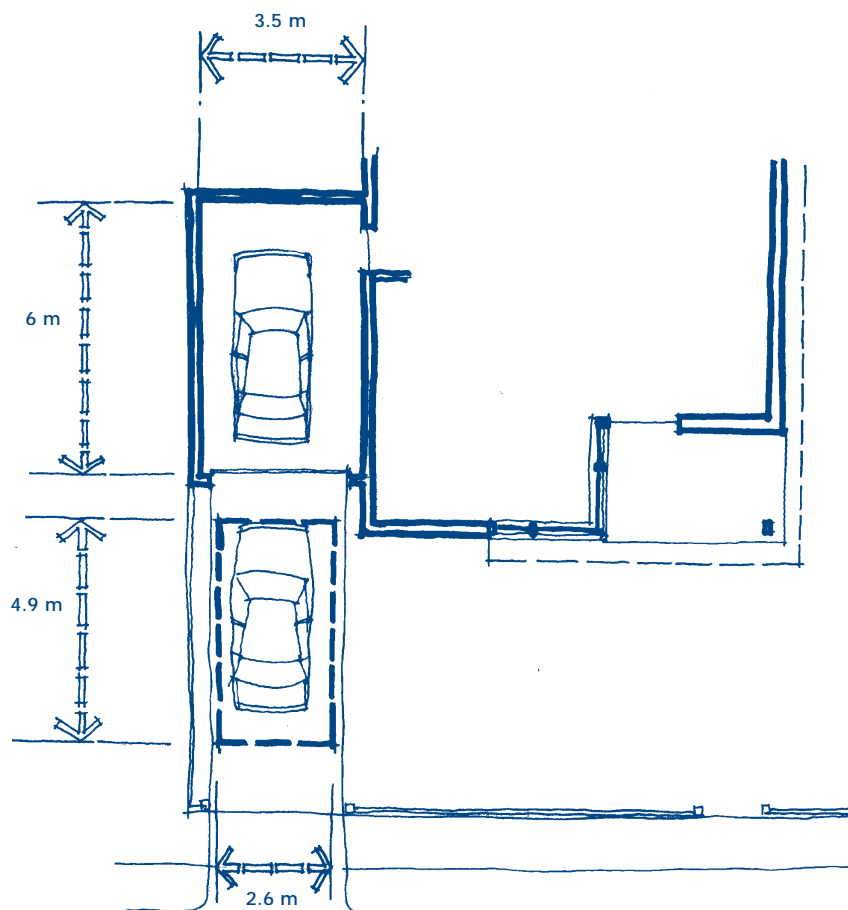

Building projection over car space

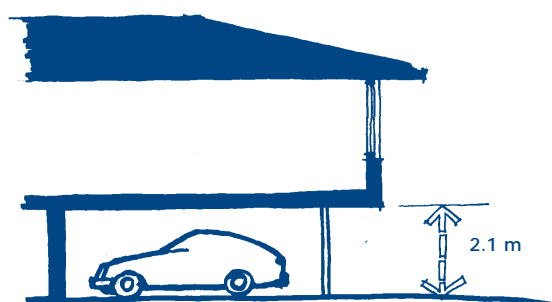

A10 B17 Side and rear setbacks

This standard ensures adequate separation between dwellings on adjacent lots, particularly above ground floor level.

Standard A10 and B17

A new building not on or within 150 mm of a boundary should be set back from side or rear boundaries:

- At least the distance specified in the schedule to the zone, or
- If no distance is specified in the schedule to the zone, 1 metre, plus 0.3 metres for every metre of height over 3.6 metres up to 6.9 metres, plus 1 metre for every metre of height over 6.9 metres.

Sunblinds, verandahs, porches, eaves, fascias, gutters, masonry chimneys, flues, pipes, domestic fuel or water tanks, and heating or cooling equipment or other services may encroach not more than 0.5 metres into the setbacks of this standard.

Landings having an area of not more than 2 square metres and less than 1 metre high, stairways, ramps, pergolas, shade sails and carports may encroach into the setbacks of this standard.

Diagram A1 and B1 Side and rear setbacks

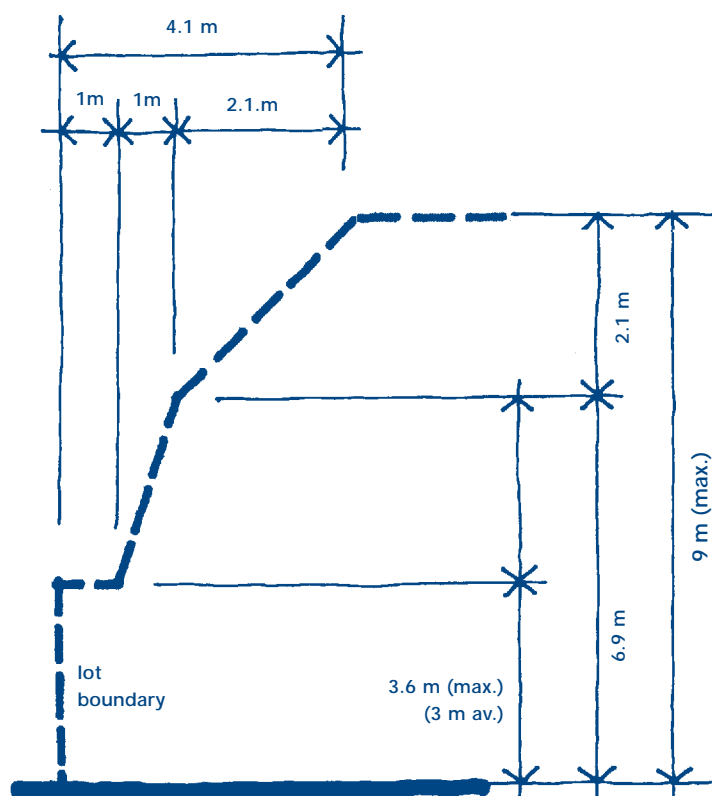

Applying the standard

Side and rear setbacks

Where the wall height is between 3.6 metres and 6.9 metres, the formula for calculating side and rear setbacks is:

$$1 \text{ m} + [0.3 \text{ m} \times (h - 3.6 \text{ m})]$$

h = wall height

Where the wall height is greater than 6.9 metres, the formula is:

$$1 \text{ m} + [0.3 \text{ m} \times (6.9 \text{ m} - 3.6 \text{ m})] + [1 \text{ m} \times (h - 6.9 \text{ m})]$$

h = wall height

Using the above example, if the wall height is 6.9 metres, the required setback is calculated as follows:

$$1 \text{ m} + [0.3 \times (6.9 \text{ m} - 3.6 \text{ m})]$$

$$1 \text{ m} + [0.3 \times 3.3 \text{ m}]$$

$$1 \text{ m} + 0.99 \text{ m}$$

$$1.99 \text{ m (rounded up to 2 m) setback}$$

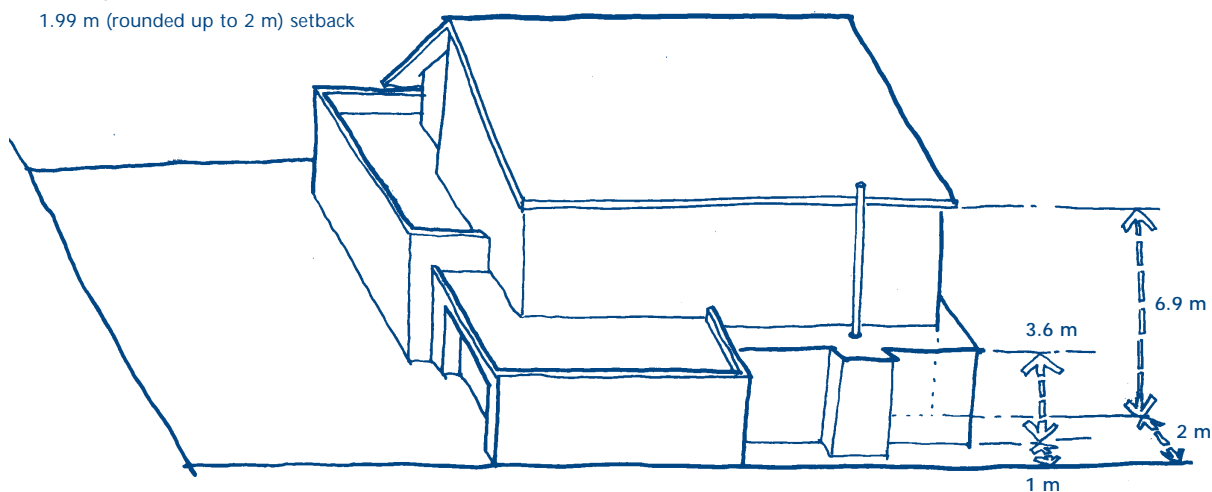

Allowable encroachments

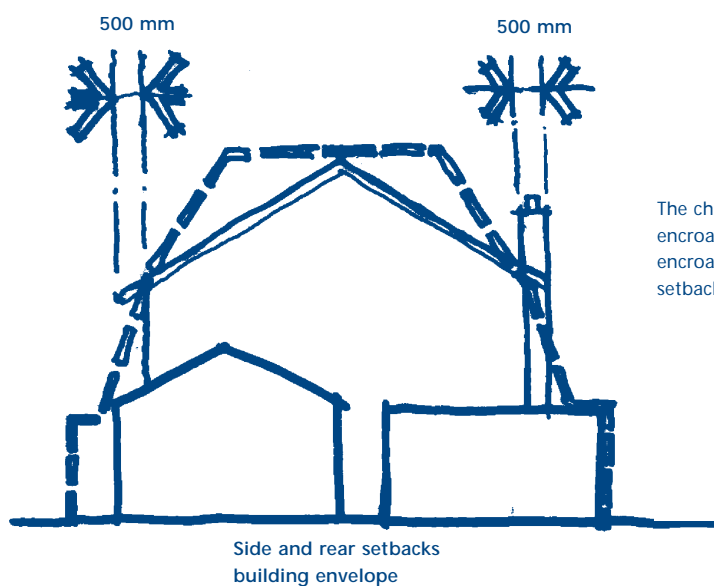

The chimney and eaves are allowable encroachments provided they do not encroach more than 500 mm into the setbacks of this standard.

A11 B18 Walls on boundaries

This standard limits the height and length of walls on lot boundaries, to reduce the impact of housing on neighbouring properties.

Standard A11 and B18

A new wall constructed on or within 150 mm of a side or rear boundary of a lot or a carport constructed on or within 1 metre of a side or rear boundary of a lot should not abut the boundary for a length of more than:

- 10 metres plus 25 per cent of the remaining length of the boundary of an adjoining lot, or
- where there are existing or simultaneously constructed walls or carports abutting the boundary on an abutting lot, the length of the existing or simultaneously constructed walls or carports,

whichever is the greater.

A new wall or carport may fully abut a side or rear boundary where the slope and retaining walls or fences would result in the effective height of the wall or carport being less than 2 metres on the abutting property boundary.

A building on a boundary includes a building set back up to 150 mm from a boundary. The height of a new wall constructed on or within 150 mm of a side or rear boundary or a carport constructed on or within 1 metre of a side or rear boundary should not exceed an average of 3 metres with no part higher than 3.6 metres unless abutting a higher existing or simultaneously constructed wall.

Applying the standard

Note. When applying this standard “new wall” means the total length of any existing and proposed wall when calculating the length of a wall on a boundary.

Walls on boundaries where there is one adjoining lot

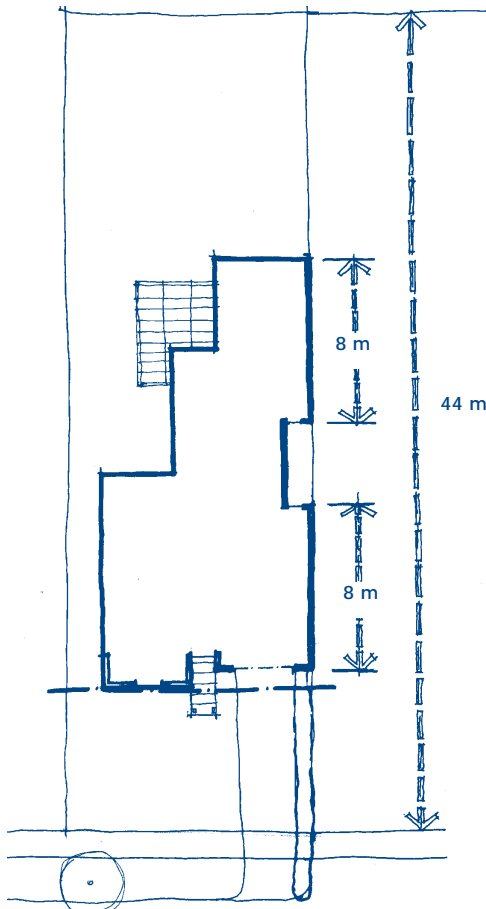

The formula for calculating walls on boundaries is:

$$10 \text{ m} + [(\text{length of boundary of an adjoining lot} - 10 \text{ m}) \times 0.25]$$

This formula is separately applied to each boundary of the lot to determine the permissible walls on each boundary of the lot.

On a lot of 44 metres in length, the walls on boundaries along this boundary is calculated as follows:

$$10 \text{ m} + [(44 \text{ m} - 10 \text{ m}) \times 0.25]$$

$$10 \text{ m} + [34 \text{ m} \times 0.25]$$

$$10 \text{ m} + 8.5 \text{ m}$$

18.5 m permissible wall on boundary.

This dwelling complies as it has less walls on boundaries than permissible under the standard. Other considerations such as neighbourhood character may be the reason for not using the maximum allowable walls on boundaries.

Walls on boundaries where there is more than one adjoining lot

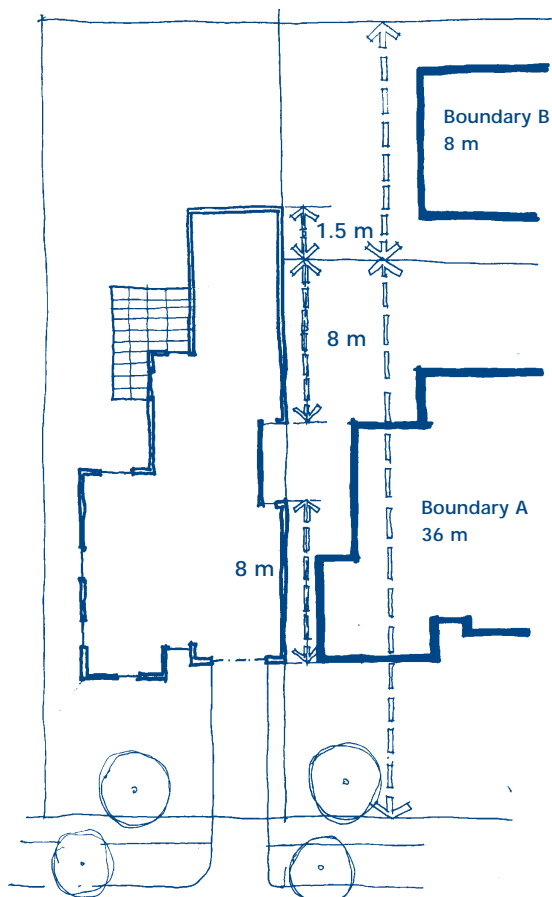

Where there is more than one adjoining lot along a boundary, walls on the boundary may be constructed up to 10 metres plus 25 per cent of the remainder of the adjoining boundary abutting the lot, for each adjoining boundary.

The walls on boundaries permitted along this boundary are:

- 16.5 metres along the adjacent lot boundary A ; and
- 8 metres along the adjacent lot boundary B.

As can be seen in this example, while the length of the boundary of the lot is the same as in the previous example (44 metres), a longer wall along this boundary is possible because of the abuttal to two properties.

To meet the standard, no part of the total permissible walls on boundaries can be longer than allowed for each adjacent lot boundary individually. For example, while the total permissible walls on boundaries is 24.5 metres, not more than 16.5 metres of wall can be built on or within 150 mm of the boundary of lot A.

Walls on boundaries where there is an existing or simultaneously constructed wall on the boundary

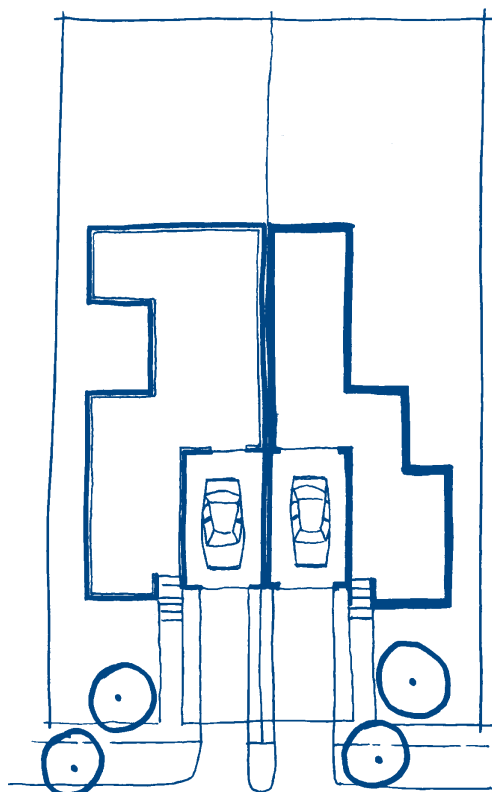

Where there is an existing wall on the adjoining boundary, the length of the permissible wall on the boundary is able to exceed 10 metres plus 25 per cent of the remainder of the boundary provided that it is the same or a lesser length of the existing wall on the boundary.

To meet the standard, no part of the new wall on the boundary can be built to extend beyond the extent of the existing wall on the boundary, even though the new wall may be the same length as the existing wall on the boundary.

Where the walls on the boundary are simultaneously constructed, they are able to exceed 10 metres plus 25 per cent of the remainder of the boundary in length.

To meet the standard, simultaneously constructed walls on the boundary must be the same length and cannot be staggered.

Effective wall height

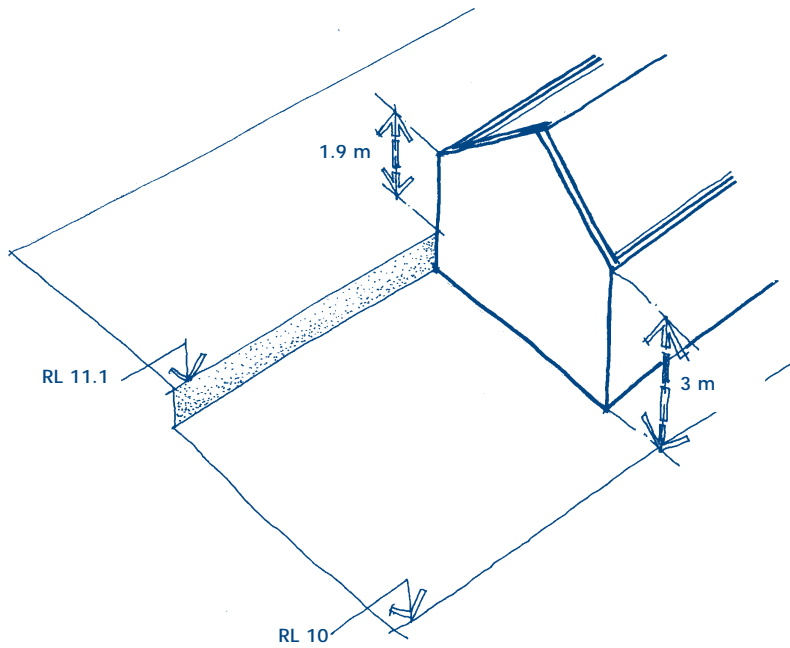

Effective wall height means the height of the wall from the top of the wall to the ground measured on the boundary from the adjoining property.

In this example, cutting and filling of the cross slope has resulted in an effective wall height of less than 2 metres on the boundary for the wall constructed on the boundary

Where the effective wall height is less than 2 metres on the boundary, the building may abut the full length of the boundary.

Height of wall on boundary

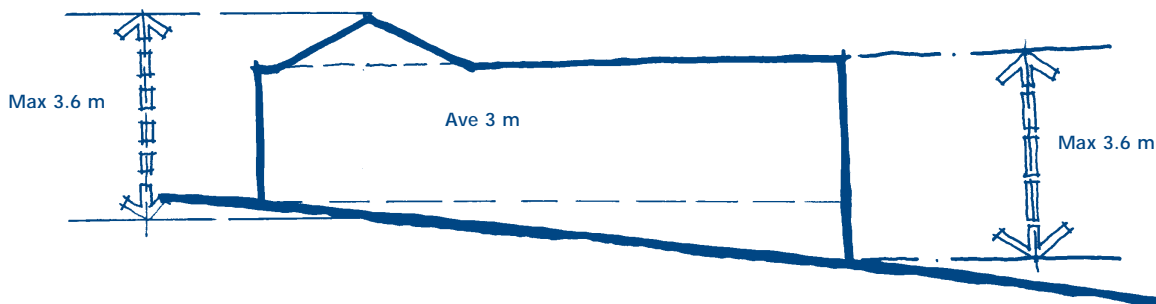

When calculating the average height of a wall on a boundary:

$$\text{Average height} = \frac{\text{Area of wall}}{\text{Length of wall}}$$

It is important to include all aspects of the wall on the boundary in the calculation, including the wall above and below the internal floor and ceiling heights of the wall.

A12 B19 Daylight to existing windows

This standard ensures that all new dwellings provide adequate daylight to existing windows.

Standard A12 and B19

Buildings opposite an existing habitable room window should provide for a light court to the existing window that has a minimum area of 3 square metres and minimum dimension of 1 metre clear to the sky. The calculation of the area may include land on the abutting lot.

Walls or carports more than 3 metres in height opposite an existing habitable room window should be set back from the window at least 50 per cent of the height of the new wall if the wall is within a 55 degree arc from the centre of the existing window. The arc may be swung to within 35 degrees of the plane of the wall containing the existing window.

Where the existing window is above ground floor level, the wall height is measured from the floor level of the room containing the window.

Diagram A2 and B2 Daylight to existing windows

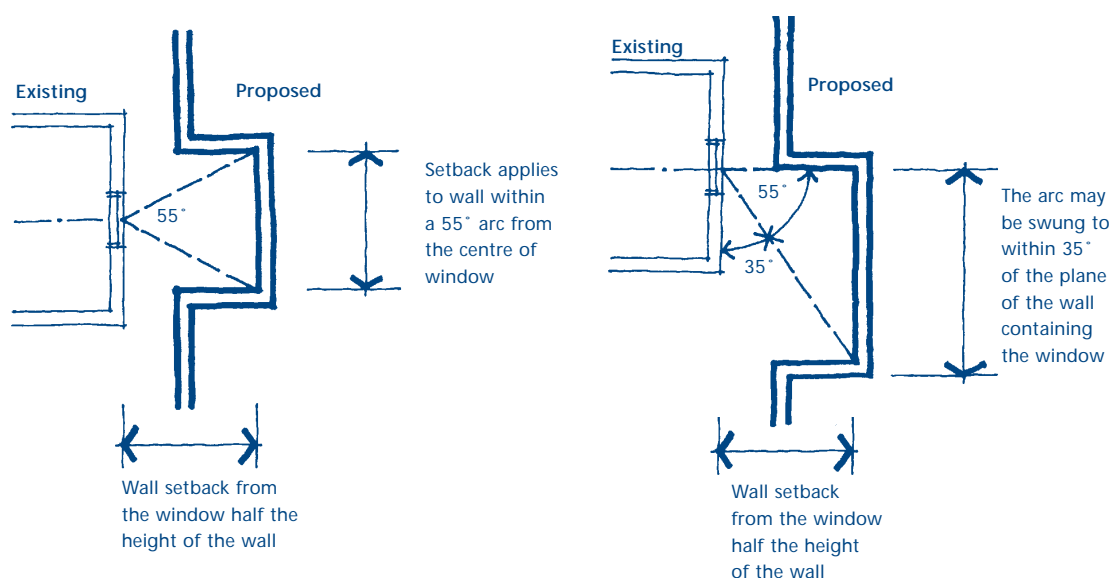

Applying the standard

Building opposite an existing habitable room window

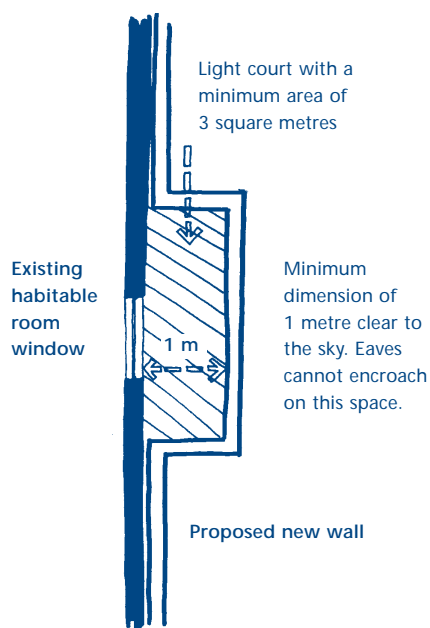

55 degree arc from centre of an existing window

Proposed new wall to be set back at least 50 per cent from the existing window if the height of the new wall is greater than 3 metres.

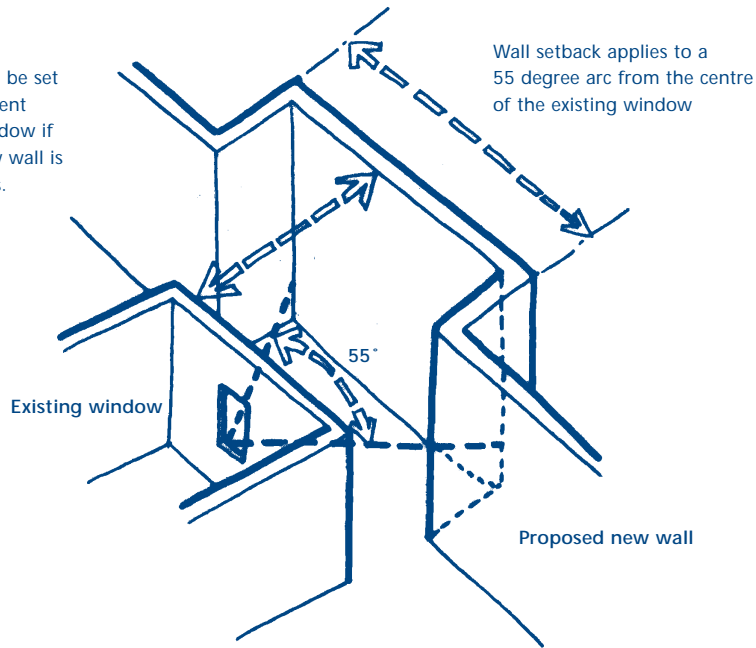

35 degree arc from the plane of an existing window

Proposed new wall setback 50 per cent of the height of the new wall if it is greater than 3 metres

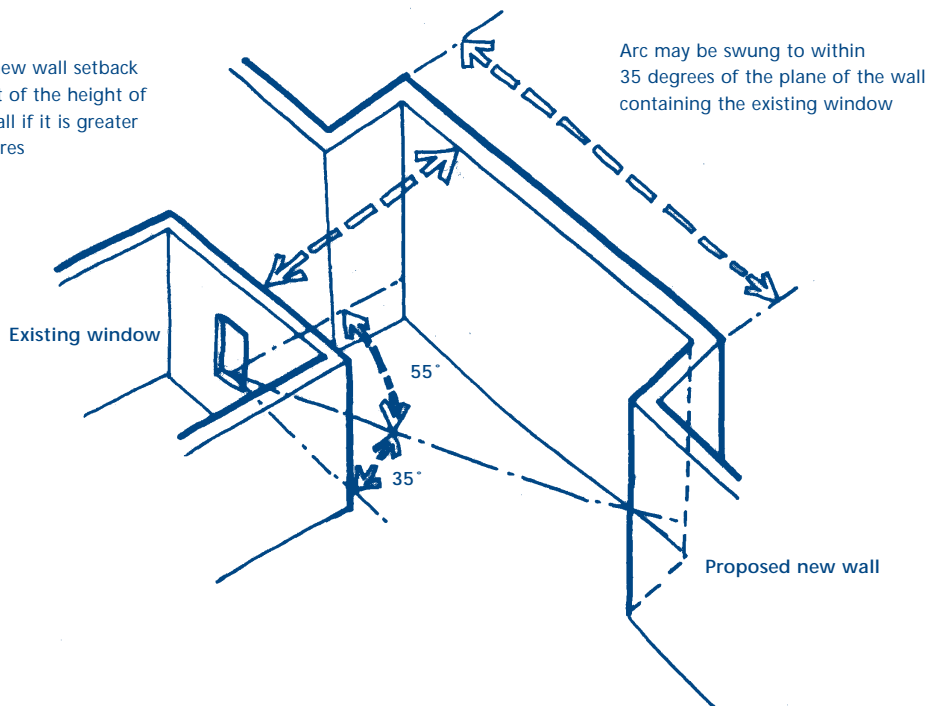

A13 B20 North-facing windows

This new standard protects the energy efficiency of existing dwellings which use north-facing windows for passive solar heating.

Standard A13 and B20

If a north-facing habitable room window of an existing dwelling is within 3 metres of a boundary on an abutting lot, a building should be setback from the boundary 1 metre, plus 0.6 metre for every metre of height over 3.6 metres up to 6.9 metres, plus 1 metre for every metre of height over 6.9 metres, for a distance of 3 metres from the edge of each side of the window. A north-facing window is a window with an axis perpendicular to its surface oriented north 20 degrees west to north 30 degrees east.

Diagram A3 and B3 North-facing windows

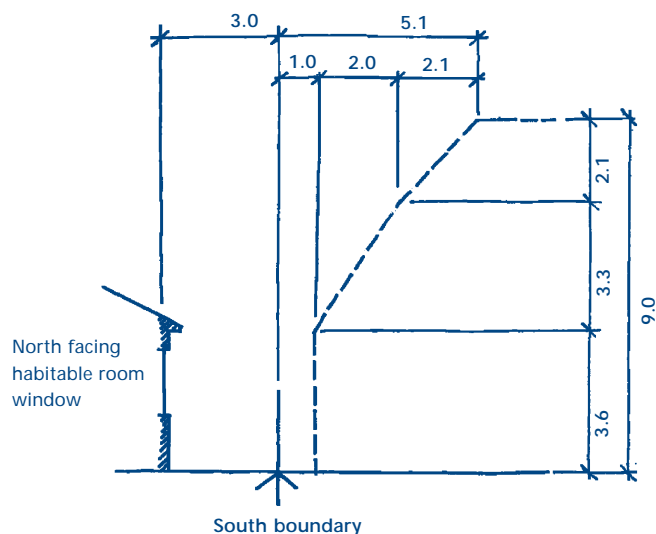

Applying the standard

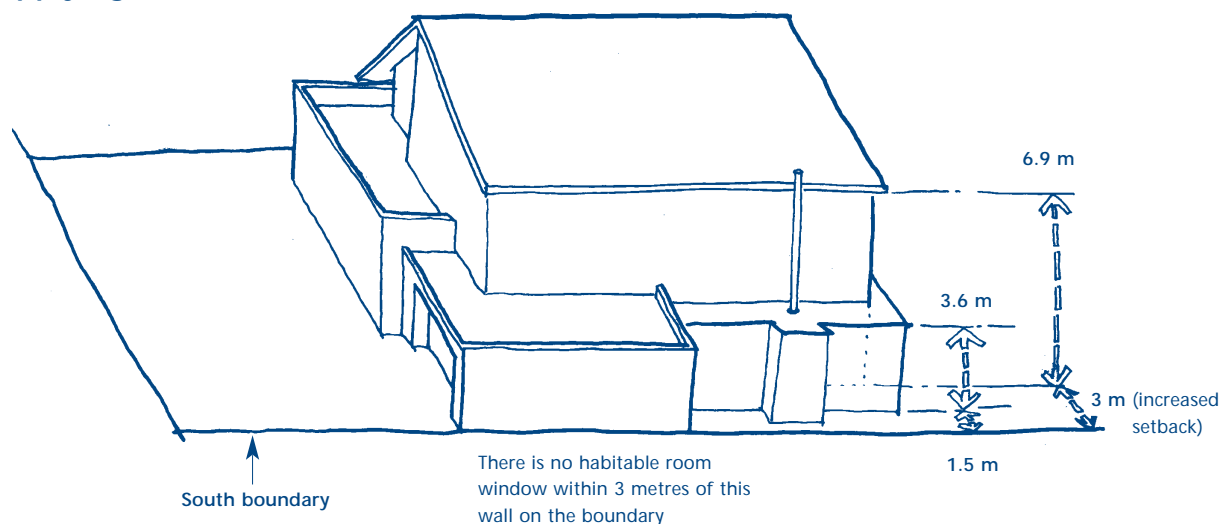

The formula for calculating the required setback where the wall height is between 3.6 metres and 6.9 metres is:

$$1\text{ m} + [0.6\text{ m} \times (h - 3.6\text{ m})]$$

h is the wall height

If the wall height is greater than 6.9 metres, the formula is:

$$1\text{ m} + [0.6\text{ m} \times (6.9\text{ m} - 3.6\text{ m})] + [1\text{ m} \times (h - 6.9\text{ m})]$$

Applying the formula to the same dwelling used in the side and rear setbacks standard, the upper storey will need to be set back a further 1 m from the southern boundary to protect sunlight to north-facing windows on an existing dwelling located to the south.

$$1\text{ m} + [0.6 \times (6.9\text{ m} - 3.6\text{ m})]$$

$$1\text{ m} + [0.6 \times 3.3\text{ m}]$$

$$1\text{ m} + 1.98\text{ m}$$

$$2.98\text{ m (rounded up to 3 m) setback}$$

A14 B21 Overshadowing of open space

This standard protects existing private open space from overshadowing from new developments.

Standard A14 and B21

Where sunlight to the secluded private open space of an existing dwelling is reduced, at least 75 per cent, or 40 square metres with minimum dimension of 3 metres, whichever is the lesser area, of the secluded private open space should receive a minimum of five hours of sunlight between 9 am and 3 pm on 22 September.

If existing sunlight to the secluded private open space of an existing dwelling is less than the requirements of this standard, the amount of sunlight should not be further reduced.

Applying the standard

Overshadowing at 9 am

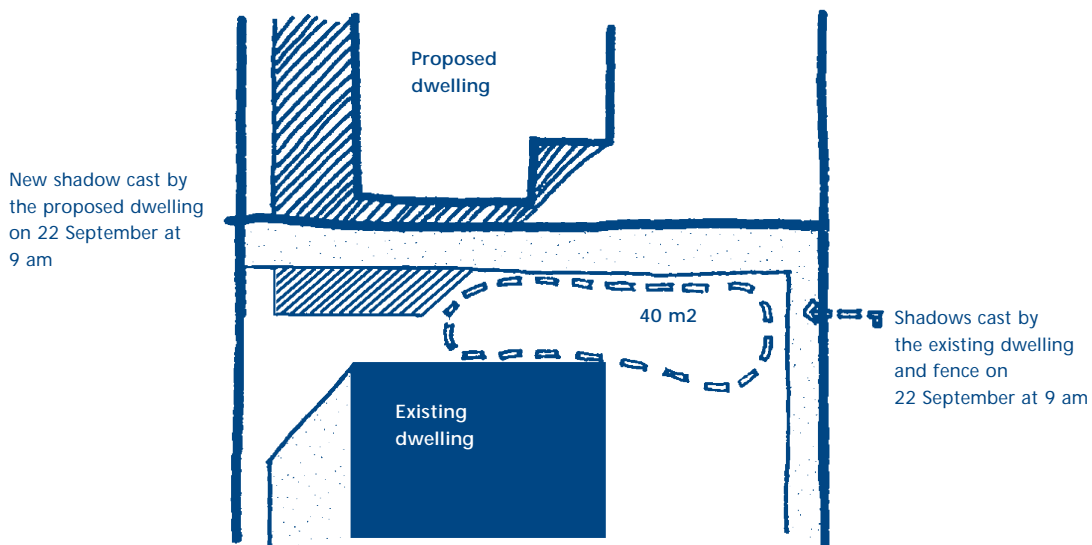

Overshadowing at 3 pm

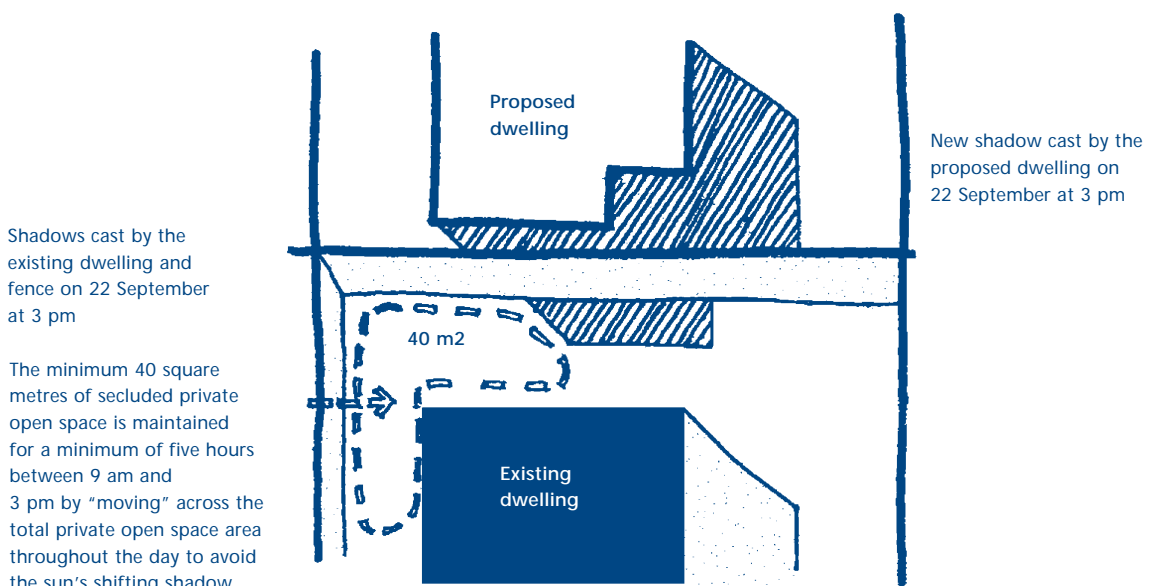

The minimum 40 square metres of secluded private open space is maintained for a minimum of five hours between 9 am and 3 pm by "moving" across the total private open space area throughout the day to avoid the sun's shifting shadow.

